

ITEM NO.	PART NO.	QTY.	DESCRIPTION
1	0882F	2	HANDLE BOSS
2	0884F	4	SOCKET HEAD SCREW, 1/4-20 BY 1-3/4
3	0886F	4	HIGH COLLAR LOCK WASHER, 1/4
4	1794F	2	U-BOLT
5	0883F	2	POST CLAMP
6	0684F	5	NYLOCKHEX NUT, 5/16-18
7	0871F	13	FLAT WASHER, 5/16
8	0881F	2	END BRACKET
9	0805F	8	CARRIAGE BOLTS, 5/16-18 BY 1
10	0781F	2	THICKNESS RAIL *
11	0779F	4	HEX BOLT, 5/16-18 BY 3-1/2
12	0791F	1	ADJUSTMENT POST/THRUST END
13	0790FB	1	CLAMP. BRACKET/THRUST END
14	0795F	1	NOSE GUARD
15	0702F	7	COUPLING NUT 5/16-18
16	0785F	2	HANDLE PLUG (ROUND)
17	0784F	1	TIE BAR
18	0778F	2	POST PLUG (SQUARE)
19	0799F	1	ON-OFF GUIDE BAR
20	0788FB	1	CLAMP. BRACKET/NOSE END
21	0793F	1	HANDLE *
22	0792F	1	ADJUSTMENT POST/NOSE END
23	0685F	2	LOCK WASHER, 5/16
24	0874F	1	GRIP
25	0596F	1	HANDLE
26	0703F	1	WRENCH
27	0875F	1	ALLEN KEY 3/16 LONG A

ALASKAN[®] MK-IV CHAINSAW MILL

MODEL G778

GRANBERG INTERNATIONAL

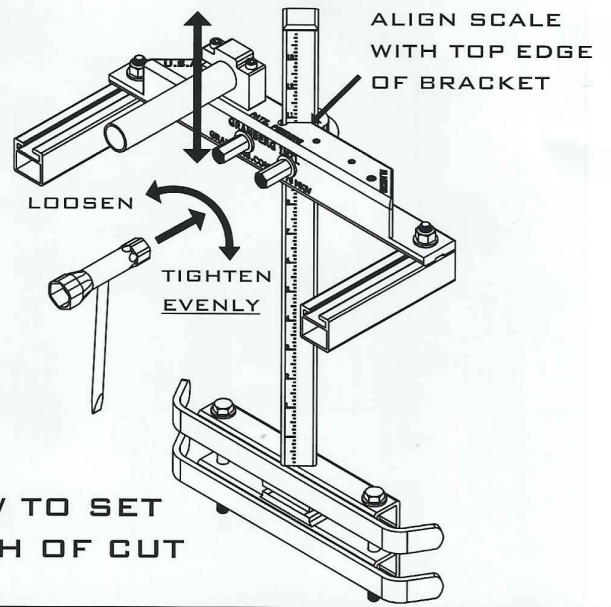

* Handle & rail sizes 24"-84" depending on mill size.

